

VERTEX VT10 SERIES PID OPERATION MANUAL

MICROPROCESSOR BASED PID CONTROLLER

1. INTRODUCTION

This manual contains information for the installation and operation and tuning of our Vertex VT10 series self-tuning microprocessor based controllers. These controllers carry a two-year factory warranty.

The VERTEX microprocessor controllers are “proportional + integral + derivative” (PID) controllers that come in a variety of standard DIN sizes. The input is configurable and allows selection or configuration of inputs between T/C, RTD, 4~20 and other linear signals and outputs between relay, SSR, heat / cool, 4~20 mA or other linear signals. They have dual displays that show the input (measured temperature) in the top digital display and the required set point in the lower. The controller boasts a comprehensive range of other features that include auto/manual function, ramp feature, and comes standard with two configurable alarms, (The VT4810 48 x 48 size only has one alarm). The controllers can be switched to manual and can work as “time based ratio out-put controllers” in the event of thermocouple or input failures taking place.

2. INSTALLATION

2.1 PANEL MOUNTING

Cut-out sizes are shown below. Panel width may be up to 10 mm thick. Do not tighten the mounting screws too tightly since this can bow the controller housing.

Table 2-1 Panel cut-out

Model	Height	Width
VT4810	45mm	45mm
VT7210	67mm	67mm
VT9610	91mm	91mm
VT4910	91mm	45mm
VT9410	45mm	91mm

2.2 CONNECTION AND WIRING

1. Power supply (Mains Supply)

These controllers require 85~265 Vdc or Vac 50/60 Hz. mains power supply. The mains should be fused by a fast blow fuse of no more than 2 amps rating. As with all electronic switch mode power supplies they are sensitive to over-voltage. If you work in an environment where surges are expected, then be sure to protect these devices with over-voltage relays. The low cost of the “over voltage device” will save you large amounts of down-time (money) by preventing problems. They are also available, as an optional extra, with an 18 ~ 32 V Dc or Ac mains input.

2. Sensor Input

Do not run sensor input cables adjacent to power carrying conductors. The correct type of thermocouple extension lead wire or compensating cable must be used for thermocouples. Ensure that the polarity of the thermocouple / 4~20 input is correct. When using 4~20 mA inputs the loop has to be powered externally by a 24 Vdc switch mode power supply. PT100 inputs require three copper core wires and can be run for up to 50 meters. You can simply select any thermocouple types in the parameter setups. To select PT100 or analog (4~20) inputs requires simple hardware changes such as de-soldering a link for PT100 etc. It is easier to simply order the controller with the correct input type.

3. Control Output

Different types of outputs are available in the controller. Be sure that the correct output type is selected for your application. Also ensure that the correct cycle time is used with the appropriate out-put type.

Available outputs are:

- Relay 5A / 240 Vac maximum, resistive load
- Pulsed voltage to drive SSR (24 Vdc)
- 4~20 mA or 0~20 mA, Maximum load 500 ohms
- Various other linear outputs (1~5Vdc, 0~5Vdc, 0~10Vdc)

Changes of out-put types are relatively simple but must be done by the supplier.

4. Alarm Output

The alarm output is a relay contact. Maximum contact rating is 10 Amps resistive load. The VT4810 has only one alarm, but all other models have two alarms.

Although the relay out-put is rated at 5 amps it is always necessary to switch an interposing relay, SSR or Contactor that will switch the load. This avoids damage to the controller in the event of a fault short developing on the power out-put circuit.

Always use a separate fused supply for the “power load circuit” and do not take this from the live and neutral terminals supplying power to the controller.

TERMINAL LAYOUT DIAGRAMS

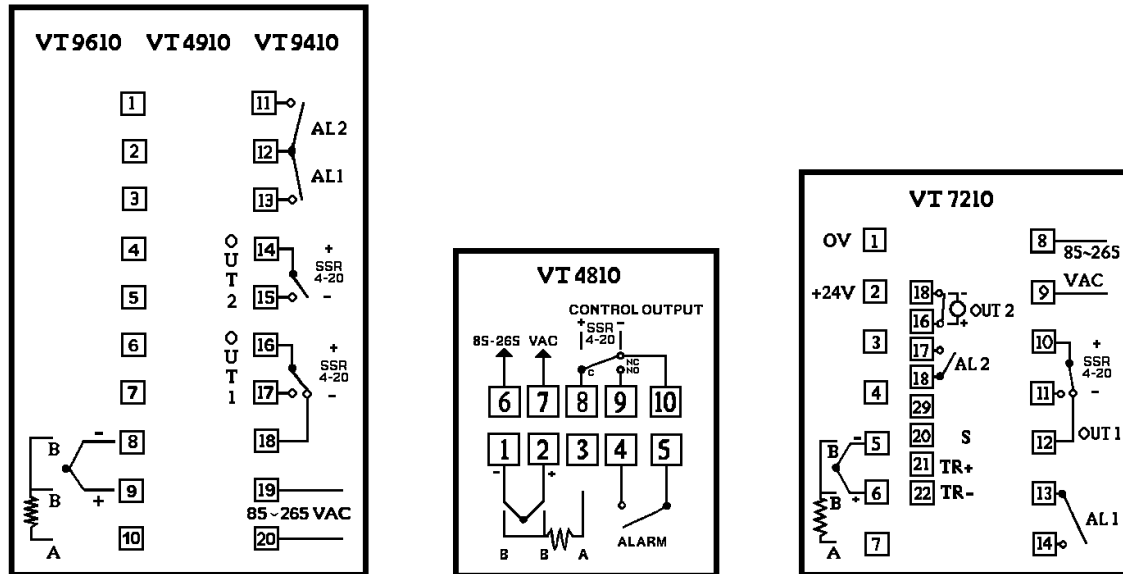

3. FRONT PANEL DESCRIPTION

PV: Process Variable

- Displays the actual measurement of the input sensor.
- When in the configuration levels it displays the parameter name being accessed.
- Displays Error messages.

SV: Setpoint Value

- Displays the required set-point setting.
- When in the configuration levels it displays the parameter value.

A1: Alarm 1 LED

- LED lights when Alarm 1 is energised.
- LED flashes if timer function is selected and activated in the alarm parameters.

A2: Alarm 2 LED

LED lights when Alarm 2 is energised.

C1: Control 1 LED

LED lights when Control Output 1 is on.

MA: Manual mode LED

LED flashes when manual control of out-put is selected.

AT: Autotuning LED

LED flashes while controller is auto tuning. (48 x 48 units have a dot on the left of the PV display that flashes).

C: Degree C LED

LED lights when programmed for degree C.

F: Degree F LED

LED lights when programmed for degree.



Scroll Key

When in one of the parameter levels, you can move from one parameter to the next by pressing the Scroll Key once.

Also to activate an autotuning session, press and hold this key for 5 seconds.



Up Key

Increases the setpoint value and changes the parameter data when programming.



Down Key

Decreases the setpoint value and changes the parameter data when programming.



Return Key

When in one of the programming levels, press this key to return to the normal operating status.

Pressing and holding this key for 5 seconds puts the controller into manual operation.

Pressing the Return Key during normal operation, allows the user to view the controller output in percentage (0~100%).

4. PARAMETER DEFINITIONS

For technical help call +44-1244-539295 or fax +44-1244-533514 or e-mail qis@qis-uk.co.uk

There are 4 levels of parameters as follows

- 4.1 OPERATING LEVEL
- 4.2 CONTROL PARAMETER LEVEL
- 4.3 CONFIGURATION LEVEL
- 4.4 CALIBRATION LEVEL (not user adjustable, consult supplier)

ENTERING PROGRAMMING LEVELS



Press and hold these keys together for 5 seconds to enter the next level of parameters.

4.1 OPERATION LEVEL (LEVEL 1)

1.

SP	Set-Point Variable
-----------	---------------------------

This parameter is the desired target for control. It can be adjusted up and down using the up/down keys when the controller is in its normal state, within the range defined by the "Low Limit" value and "High Limit" value.

2.

rRñP	Ramp Rate	0.0~100.0 °C/min
-------------	------------------	-------------------------

This forces the controller to ramp from the actual temperature at the time the controller is switched on, to the control set-point, at the pre-set ramp rate (number of degree's centigrade per minute) as defined by this value. To activate this parameter select a parameter lock setting (see "Level 3" item 2) that allows access to the **rRñP** feature. The **rRñP** parameter will then be accessible in "level 1" where you can set the ramp rate. Set this parameter to zero if no ramp function is needed. You can select a rate from 0.0 ~ 100.0 deg C/min. If this feature is selected, each time you make a setpoint change, it will ramp at the preset ramp rate from where it was to the new setpoint.

3.

oPoF	Output offset Value for Manual Reset	0~100 % of full scale
-------------	---	------------------------------

This is in essence a “manual reset” function. It can be used to alter the PV reading by introducing a fixed off-set. This can be used to correct the relationship between the PV reading and the SV reading. Under normal circumstances this should be set to “0”.

4.	AISP	Alarm 1 Setpoint Value	full scale
----	-------------	-------------------------------	-------------------

This sets the value at which alarm 1 will operate if “A1Fu” 0 or 5, 1 or 5, 2 or 6, 3 or 7, 12 or 14 or 13 or 15 is selected for alarm function. If the time based alarm functions 8, 9, 10 or 11 are chosen, this parameter will not be shown. You will use the **tiñE** setting instead. Time based functions are only available on alarm 1.

5.	A2SP	Alarm 2 Setpoint Value	full scale
----	-------------	-------------------------------	-------------------

This sets the value at which alarm 2 will operate if “A1Fu” 0 or 5, 1 or 5, 2 or 6, 3 or 7 is selected for alarm function.

6.	tiñE	Dwell Time	0~9999 min’s
----	-------------	-------------------	---------------------

This parameter sets the “time value” to be used in the “A1Fu” time based alarm function. (“A1Fu” set to 8, 9, 10 or 11).

This parameter is available only in the case that the “A1Fu” is set to timer function.
The range available is from 0 to 9999 minutes.

4.2 OPERATION LEVEL (LEVEL 2)

1.	Pb	Proportional Band Setting	0.0 to 100.0% of controller’s span
----	-----------	----------------------------------	---

Setting range from 0.0 to 100.0% of controller’s span as set by LoLt and HiLt
This value can be automatically calculated by activating the Autotune Function.
Set to zero for ON/OFF control action.

2.	C Pb	Cooling Prop Band Setting	multiplication factor 0.0 ~ 10.0
----	-------------	----------------------------------	---

This value is the proportional band setting for the “cooling out-put” if that option is available on the controller.

It is set as a multiplication factor of the main out-put Pb value.

The default value is 1.0 which means that the C Pb value will equal the main Pb setting
 $C Pb = Pb \times \text{factor}$

3.	ti	Integral Time (Reset)	0~3600 sec
----	-----------	------------------------------	-------------------

Setting range from 0 to 3600 seconds.

This value can be automatically calculated by activating the auto tune function.

4.	td	Derivative (Rate)	0~3600 sec’s
----	-----------	--------------------------	---------------------

0 to 3600 seconds setting range.

This value can be automatically calculated by activating the auto tune function.

5.	db	Dead Band Value	-10.0%~ 10.0%
----	-----------	------------------------	----------------------

This function sets the dead-band between the heating and cooling out-puts.

Setting range from -10.0% to 10.0% of Pb.

4.3 CONFIGURATION LEVEL (LEVEL 3)

1.	rEño	Remote/Local Mode Selection
----	-------------	------------------------------------

Set to 0 for local mode or 1 for RS485 remote mode.

In remote mode, all parameters can not be changed using the front panel keypad.

If not using remote comms, this is a way of locking all parameter settings from the operating staff.

2.

P-L	Parameter Lock
------------	-----------------------

Permits the user to lock (prevent changes) for different levels as shown in the table below.
The levels can be adjusted wherever there is a ●
Other parameters can be locked using other means (see Item 5 below)

P-L	rAñP	PyoF	AISP tiñE	A2SP	2 nd Level	3 rd Level	4 th Level
0			●	●	●	●	●
1	●		●	●	●	●	●
2		●	●	●	●	●	●
3	●	●	●	●	●	●	●
4			●	●	●	●	
5	●		●	●	●	●	
6		●	●	●	●	●	
7	●	●	●	●	●	●	
8			●	●	●		
9	●		●	●	●		
10		●	●	●	●		
11	●	●	●	●	●		
12			●	●			
13	●		●	●			
14		●	●	●			
15	●	●	●	●			

● Parameters can be adjusted

Note: No adjustments should be made in 4th level under any circumstances

3.

A IFu	Alarm 1 Function.	See Table 1
--------------	--------------------------	--------------------

Alarm one's mode of operation is selected according to the table.

4.

A 2Fu	Alarm 2 Function.	See Table 1
--------------	--------------------------	--------------------

Alarm two's mode of operation is selected according to table.

5.

A IHy	Alarm 1 Hysteresis	0.0 to 25% of controllers span
--------------	---------------------------	---------------------------------------

Setting range 0.0 to 25% of controllers span as defined by HiLt and LoLt. Used to eliminate relay "chatter". This will create a HySt band with 50% of the HySt value above the setpoint and the other half below.

6.

A 2Hy	Alarm 2 Hysteresis	0.0 to 25% of controllers span
--------------	---------------------------	---------------------------------------

Setting range 0.0 to 25% of controllers span as defined by HiLt and LoLt. Used to eliminate relay "chatter".
This will create a HySt band with 50% of the HySt value above the setpoint and the other half below.

7.

Act	Control Output Action
------------	------------------------------

Set to 1 for heating (reverse) action. 0 for cooling (direct) action.

8.

unit	Process Value unit of measure
-------------	--------------------------------------

Set to 1 for degrees C, 0 for degrees F, or 2 for other linear process.

9.

dP	Decimal Point Selection
-----------	--------------------------------

This parameter defines the position of the decimal point on the process value and Set-point.
Can be set to 1 for PT100 or linear inputs (4~20 mA).

10.

Ct	Proportional Cycle Time of Output 1	15 sec's
-----------	--	-----------------

The value can be set from 0 to 100 seconds.

Set to 1 second for SSR output.

Set to 0 seconds for 4~20 mA output.

Set to 15 seconds or longer for relay out-put to prolong relay life.

11.

C Ct	Proportional Cycle Time of Output 2	15 sec's
-------------	--	-----------------

12.

HySt	Hysteresis (Dead Band) for ON/OFF control
-------------	--

User can set a range from 0.0 to 25.5% of SPAN.

When used in the on/off mode (i.e. Pb set to 0) this parameter will set the dead-band around the set-point.

The temperature will rise to the set-point then will have to cool down through the dead-band before switching on again.

13.

EroP	Failure mode out-put status	See table 2
-------------	------------------------------------	--------------------

This setting defines the failure status of the out-puts in the event of a failure such as thermocouple break etc.

14.

Addr	Address for RS485 Communication
-------------	--

15.

PyoF	Process Value Offset	-100.0°C ~ 100.0°C.
-------------	-----------------------------	----------------------------

This parameter allows for manual compensation of any process off-set that may exist between the measurement of the probe and the reading on the controller.

16.

tYPE	Input Type Selection
-------------	-----------------------------

Type	Input Sensor Type	Range
0	J	-50°C ~ 1000°C
1	K	-50°C ~ 1370°C
2	T	-270°C ~ 400°C
3	E	-500°C ~ 750°C
4	B	0°C ~ 1800°C
5	R	0°C ~ 1750°C
6	S	0°C ~ 1750°C
7	N	-50°C ~ 1300°C
8	PT 100 DIN	-200°C ~ 500°C
For T/C G1 on PCB must be soldered		
For PT100 it must be open		
9	PT 100 JIS	-200°C ~ 500°C
10	LINEAR (4~20)	-1999 ~ 9999
The change to linear input must be done by the supplier		

17.

LoLt	Low Limit Range
-------------	------------------------

This parameter sets a low limit. Bear in mind that when the measured variable drops below this value, the controller will consider that it is out of range as if the probe (thermocouple) has failed and all outputs will behave in accordance with the **EroP** parameter selected. The PV display will flash while the value is out-side these parameters. It is not good practice to use this parameter as a means of restricting the operator from going below a low setpoint limit.

18.

HiLt	High Limit Range
-------------	-------------------------

This parameter sets a high limit above which the operator cannot set the set-point. Bear in mind that when the measured variable goes above this value, the controller will consider that it is out of range as if the probe (thermocouple) has failed and all outputs will behave in accordance with the **EroP** parameter selected. The PV display will flash while the value is out-side these parameters.





4.4 **CONFIGURATION LEVEL (LEVEL 4)**

These settings are only for factory adjustment

1.	LoCA	Low Calibration Value
2.	HiCA	High Calibration Value
3.	tunE	Auto-tuning Selection

5. **OPERATIONAL FEATURES**

5.1 **AUTO / MANUAL CONTROL MODES**

- The manual function can be locked by pressing the  and  keys together for 5 seconds.
- The function is unlocked by pressing the  and  keys together for 5 seconds.
- Once this feature is unlocked, to change from auto to manual and back again, press the  key for five seconds. When in manual there will be a "dot" flashing in the extreme right hand lower corner of the SV display.
- Automatic Control**
In auto mode, the controller automatically adjusts the output variable in accordance with the PID algorithm to reach and maintain the desired set-point. Auto mode is the normal mode of operation. It is normally PID control (depending on the parameters you select for the P, I, + D parameters)
- Manual Control**
Manual control allows the operator to control the out-put by forcing it up or down using the keys. With a 4~20 mA out-put controller the out-put can be increased or decreased by manually adjusting it using the up and down keys. With a relay out-put controller, when in manual you are able to vary the relationship between the on and off times, thereby adjusting the power fed to the load. This is measured in % of cycle time in seconds. So 40 % would cause the load to be on for 40 % of the cycle time and off for 60%. (Cycle time for a relay out-put controller is usually set at 15 seconds). This is a useful feature that can be used in the event of a T/C break to keep production running.

5.2 **AUTOTUNE**

The auto-tune feature will work when it should depending on the "tune" parameter selected below. This is normally set at "1" which means the controller requires an instruction to perform an auto-tune operation. This is best as in most cases once the controller has been set up one does not wish to keep changing the parameters. To affect an auto-tune operation you need to allow the controller to reach the set-point and then press and hold the scroll key  for 5 seconds until the auto-tune dot in the right extreme of the PV display starts to flash. The controller will then perform an auto-tune operation until the light stops flashing. Normally this will be two or three cycles of control.

tunE	Auto-tune parameter selection.
0	Tune at set-point when instructed to do so manually.
1	Tune at 10% below set-point when instructed to do so manually.
2	This causes the controller to effect a once only auto-tune cycle on initial power up that will be done at the PV. It will then reset itself to 0 (tune=0) on completion to prevent further auto-tuning at consecutive power ups.
3	This causes the controller to effect a once only auto-tune cycle on initial power up that will be done at 10% below the setpoint. It will then reset itself to 1 (tune=1) on completion to prevent further auto-tuning at consecutive power ups.
4	This causes the controller to effect auto-tune at every power up that will be done at the setpoint.
5	This causes the controller to effect auto-tune at every power up that will be done at 10% below the setpoint.

5.3 RAMP

The controller can be configured to act either as a fixed set-point controller or as a single ramp on power up controller. This function enables the user to set a predetermined ramp rate to allow the process to gradually reach set-point temperature thus producing a “soft start” function. This parameter is activated by selecting the appropriate parameter lock level that will allow access to the rAnP function, ie: 1, 3, 5, 7 etc. The ramp function is also automatically engaged when making set-point changes. This means that the controller will ramp the temperature from the current value to the new set-point value in accordance with the ramp setting. The ramp rate is determined by “**rRñP**” parameter, which can be set in the range 0.0 to 100.0°C/minute. The ramp function is disabled when the **rRñP** parameter is set to zero. Note that if the **LoLt** is set above 0°C the output will be governed by the failure mode selected in **EroP** and will not ramp or control at all until the measured variable has exceeded the **LoLt**.

5.4 RAMP AND DWELL

A dwell timer is incorporated in the certain alarm functions and can be used with the ramp function to effect single step ramp and soak control. Alarm 1 can be configured by setting “**A 1Fu**” = 9 activate this feature. To achieve this you must wire the contactor output in series with the alarm contact. After setting the “**A 1Fu**” = 9 you will find the **tñE** function displayed in the user level. This is where you will set the soak time in minutes. On turning the controller on the alarm contact will be on, allowing the controller to control the temperature. Once the SV = SP the timer will be started. The alarm light will flash to indicate that the soak timer is running. At the end of the pre-set time, the alarm relay will switch off and the output will be disabled. This time alarm function can be used without the ramp, simply to set a soak time for the controller and then switch it off. To deactivate the timer function temporarily just set the time to -1 minutes or remove the function from the “**A 1Fu**” settings.

5.5 HEATING / COOLING CONTROL

There are two ways of doing this.

Using the Alarm for the cooling:

It is not always necessary to use proportional control for cooling as often cooling is done with some type of refrigeration equipment or fan, that cannot be turned on and off on a frequent basis. In this case you use the standard off the shelf controller that comes complete with an alarm. By configuring the alarm as a deviation alarm “**A Ifu=0**” it links the alarm to the set-point by a fixed deviation, and the alarm out-put can then be used for cooling. The alarm setting in level 1 then dictates the gap between the heating setpoint and the “alarm” cooling setpoint. The alarm also has its own hysteresis setting thereby allowing you to set a band on the cooling set point (alarm setting) that will dictate how far the temperature must drop before cooling (alarm) switches off again. This is the “**A lhy**” setting. In addition to this since the alarm is linked to the main set point as you change the set point the cooling parameters follow and do not need to be readjusted each time. This method is often used for “fan” cooling on extrusion barrel heaters

Purchasing a controller with a second proportional control output.

An option is available in these controllers is a second proportional control output that can be used for cooling. This means you will have PID control on the heating output, and proportional control on the cooling. Note: A second proportional cooling output is not available on the 48 x 48 size. This type of proportional control can be used when you have liquid cooling on an extrusion barrel, where you are switching a solenoid valve to control the cooling.



5.6 ERROR MESSAGES

AdEr	A/D converter damage
Open	Sensor break error...faulty input
AtEr	Incorrect operation of autotune procedure
CSEr	Check sum error, value in memory may have changed accidentally

TABLE 2

EroP	Alarm 2	Output 2	Alarm 1	Output 1
0	Off	Off	Off	Off
1	Off	Off	Off	On
2	Off	Off	On	Off
3	Off	Off	On	On
4	Off	On	Off	Off
5	Off	On	Off	On
6	Off	On	On	Off
7	Off	On	On	On
8	On	Off	Off	Off
9	On	Off	Off	On
10	On	Off	On	Off
11	On	Off	On	On
12	On	On	Off	Off
13	On	On	Off	On
14	On	On	On	Off
15	On	On	On	On





5.7 ALARM FUNCTIONS

The Alarm function can be locked by pressing the  and  keys for 5 seconds.

The Alarm function can be unlocked by pressing the  and  keys for 5 seconds.

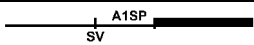
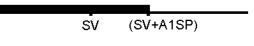
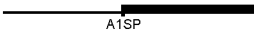
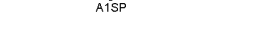
Select the type of alarm function required from the table below. Use **AISP** to set values as required.

TABLE 1

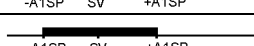
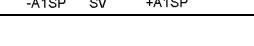
<i>A lfu</i>	<i>A 2Fu</i>	ALARM OPTION SETTINGS	
0 or 4	0 or 4	Deviation Alarm High Alarm output on when $PV > (SV + A1SP)$	
1 or 5	1 or 5	Deviation Alarm Low Alarm output on when $PV < (SV - A1SP)$	
2 or 6	2 or 6	High Alarm	
3 or 7	3 or 7	Low Alarm	
8	-	Timer Function Timer on when $PV = SV$ alarm on when timer off	
9	-	Timer Function Alarm on when power on, off when timer OFF	
10	-	Timer Function Alarm output ON when timer on	
11	-	Timer Function Alarm On when power on, off when timer ON	
12 or 14	-	Band Alarm	
13 or 15	-	Band Alarm	

Note: In each case where a second option is available as in 4, 5, 6, 7, 14 and 15, these options include an inhibit on start up. On start-up the alarm will only become active once the measured variable has reached the active alarm zone and dropped below that for the first time.

7. SPECIFICATIONS

1. INPUT

- Thermocouple J, K, T, E, B, R, S, N (IPTS68/DIN 43710)
- RTD Pt100 ohms RTD (DIN 43760/BS 1904 or JIS)
- Linear Voltage (Current) 0~20 mA and 4~20 mA
- Range User configurable (To best suit application)
- Accuracy T/C ± 1.0 °C, RTD 0.2 °C
- Cold Junction Compensation 0.1% (ambient typical)
- Input Impedance 10M ohms for T/C, 100K ohms for Linear Voltage, 2.7 ohms for 4~20mA
- Excitation Current for RTD 0.2mA Maximum
- Sample Rate 250 mS
- Common Mode Rejection 120 dB
- Normal Mode Rejection 60dB

2. CONTROL

- Proportional Band 0.0 ~ 100.0% (of full scale)
- Integral (Reset) 0 ~ 3600 Seconds
- Derivative (Rate) 0 ~ 3600 Seconds
- Anti Rest Windup Inhibits integral action outside Proportion Band
- Ramp Rate 0.0 ~ 100.0 °C/ minute
- Dwell 0 ~ 9999 minutes
- On-Off With adjustable hysteresis
- Cycle Time 0 ~ 99 Seconds
- Control Action Configurable for Direct (Cooling) or Reverse (Heating)
- Alarm functions 16 configurable different functions available

3. OUTPUT

- Relay 5A/240 VAC resistive
- Pulsed Voltage SSR Isolated 24 VDC 100mA Maximum
- Current 4~20 mA Isolated 0 (4)~20mA Maximum load 500 ohms
- Alarm Relay out. Form A contact (SPST) 10A/240 VAC resistive

4. MAINS POWER

- Standard 85 ~ 265 VAC 50/60 Hz
- Optional (low voltage) 18~32 V dc/ac
- Consumption 5 VA maximum

5. ENVIRONMENTAL

- Operating Temperature 0~ 50 °C
- Humidity 0 ~ 90%
- IP rated IP63
- Insulation 20M ohms minimum @ 500 VDC
- EMC Emission EN 50081-1:1992, EN 55022:1994
- EMC Immunity EN 50082-1:1992, IEC 801-2, IEC801-3, IEC 801-4:1988
- Weight VT4810 -180g, VT9410, VT4910 & - 240g, VT7210 - 230g

Parameter Flow Chart

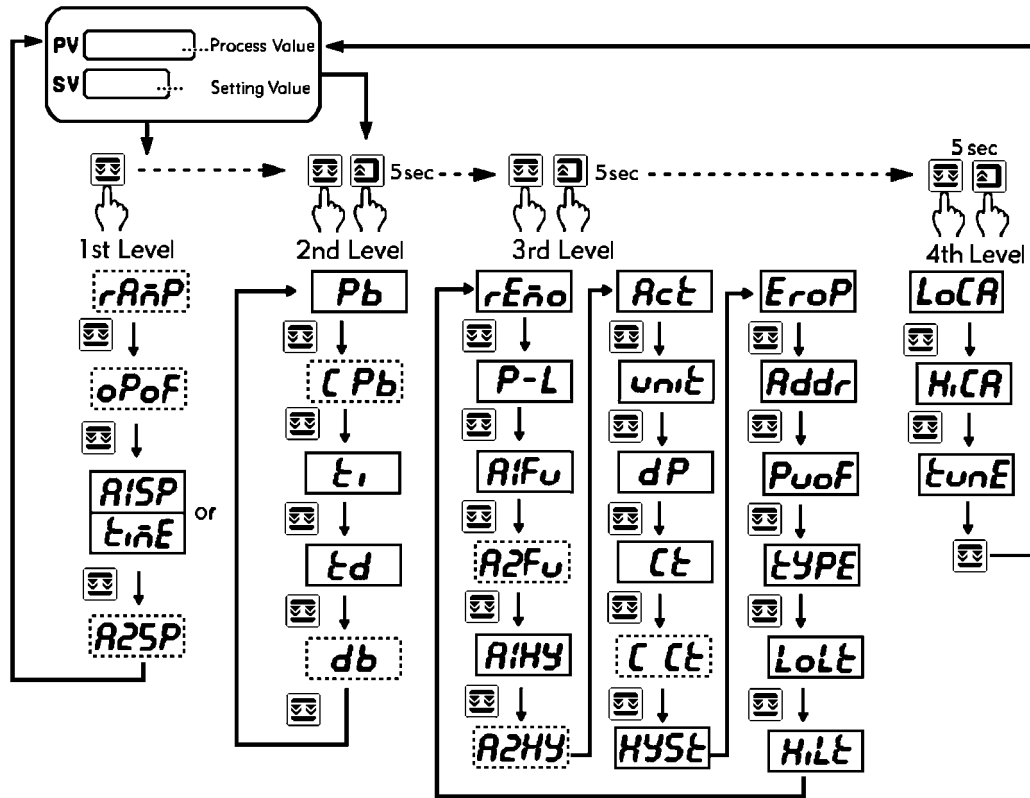

Technical Help

+ 44 1244 539295